

## SQUARE EMERGENCY LIGHT

Date:..... Location: .....

Product:.....Project:.....

Quantity:..... Catalog# .....



### ► Electric Characteristic

Model NO	Input Wattage	Input Current	Efficiency	Recharge Time	Output Wattage	Light Source	Lead-Acid Battery	Emergency duration	Product Size
LS-EML033	2.4W	0.02A	0.97P	24H	2*1.2W	Ultra bright LED	3.6V/600mAh	>90mins	11.02"*4.56"*2.67"

### ► DIMENSION

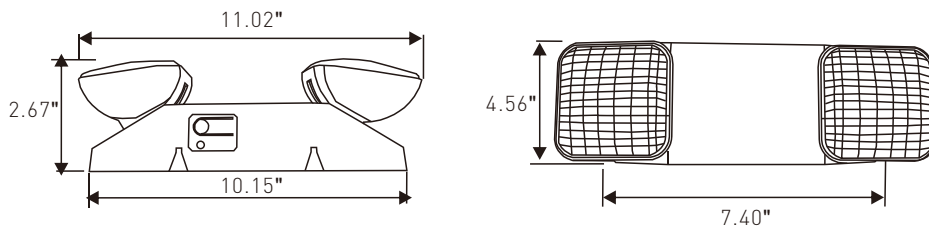

### IMPORTANT SAFETY GUIDES

- When using electrical equipment, basic safety precautions should always be followed including the following
- When using electrical equipment, Turn off all electrical power before installation.

### READ AND FOLLOW ALL SAFETY INSTRUCTIONS

- When using electrical equipment, basic safety precautions should always be followed, including the following:
- Read and follow all safety instructions.
- Disconnect power before performing work on electrical equipment.
- Do not use outdoors.
- Do not let power cords touch hot surfaces.
- Do not install in hazardous locations or near gas or heaters.
- Do not use this equipment for other than its intended purpose.
- Servicing of this equipment should be performed by qualified service personnel.
- Equipment shall be mounted in locations at heights where it will not be subject to tampering by unauthorized personnel.

# SQUARE EMERGENCY LIGHT

- Allow battery to be charged for 24 hours before first use.
- Save these instructions:

## INSTALLATION(J-BOXMOUNTING):

- Feed fixture leads through main bottom case and connect AC power supply(Fig A).
  - Connect wires through J-Box .Main bottom case on J-Box and secure with screws.
  - Connect battery only after continuous AC power can be provided to the unit(Fig B) .
  - Align snaps and push housing directly onto main bottom case(Fig C) apply continuous AC power and press"TEST" button to check light.
- WARNING: Unused wires must be capped using using enclosed wire nuts.

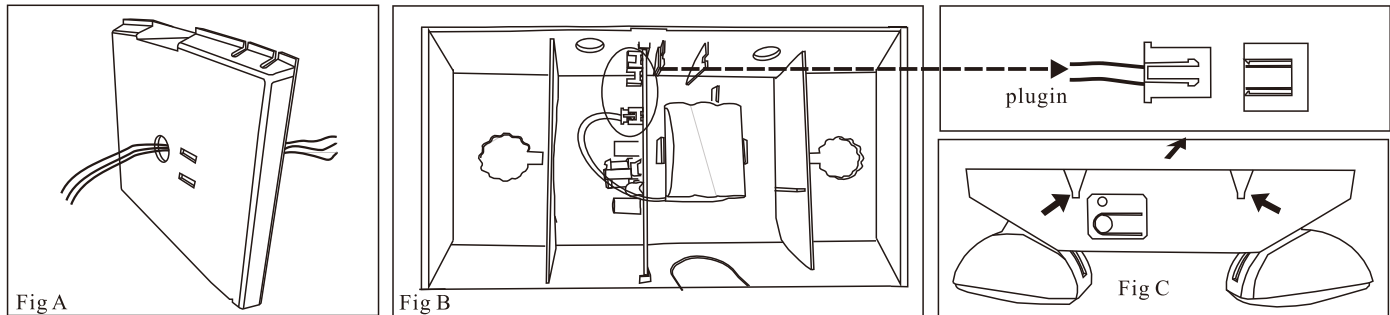
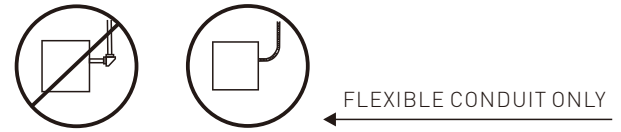

## INSTALLATION(CONDUIT):

- Secure main bottom case to wall surface.Route wires through hole in conduit flange and make conduit connection.Connect battery only after continuous AC power can be provided to the unit(Fig B).
- Align snaps and push housing directly onto main bottom case(Fig C).Apply continuous AC power andpress"TEST"" button to check light.

## OPERATION:

- During an electrical power failure, the lamps will automatically come on for a minimum of 90 minutes.
- To test ,depress the"TEST" switch , the emergency lamps will illuminate. When the switch is released , the lamps will go off.

## Features:

- Injection-molded thermo plastic housing,UL94V-0 flame rating.
- Innovative,easy installation in minutes.
- Suitable for wall mount applications.
- Universal J-box mounting pattern.
- 120V;277VAC Dual voltage operation.
- 2pcs 1.2W ultra bright LED lamp heads for emergency mode.
- Luminous flux:more than 150Lm.
- Built-in 3.6V/600mAh Nickel cadmium battery for minimum 90 minutes emergency operation.
- Maximum 24 hours for full recharge time.emergency mode.
- Test switch and charge indicator.
- 5 Cto 40°C indoor damp location listed.
- product size

## WIRING DIAGRAM:

### ADJUST LAMP HEADSAND LENS:

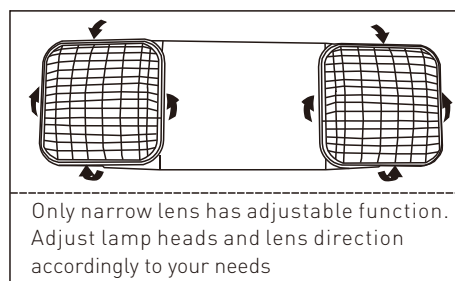
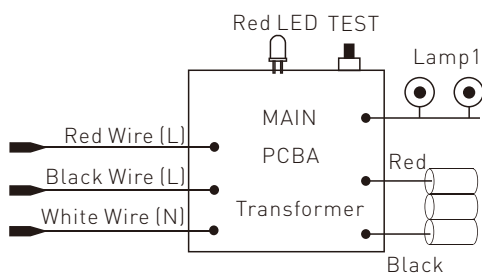

# SQUARE EMERGENCY LIGHT

## INSTALLATION DIAGRAM

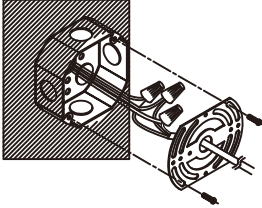
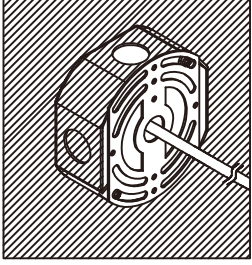
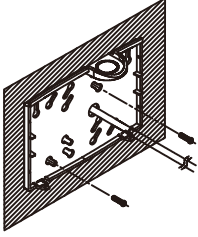
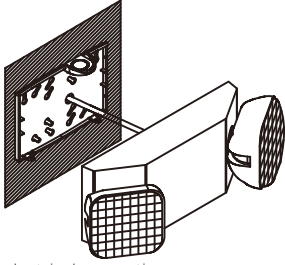
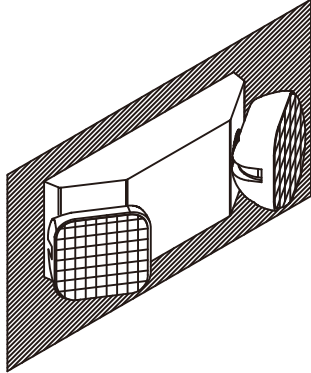
	 <p>1</p> <ol style="list-style-type: none"> <li>1. Using a flat screw driver, remove the front cover, Remove and discard the canopy kit.</li> <li>2. Feed excess wires into the junction box.</li> <li>3. The system can accept input voltages of 120VAC or 277 VAC .Therefore, connect the black wire (line voltage) and the white wire (common) leads to the building utility. Connect the green ground</li> </ol>	 <p>2</p> <ol style="list-style-type: none"> <li>1. Using the junction box screws to mount spider plate on to junction box.</li> </ol>
 <p>3</p> <ol style="list-style-type: none"> <li>1. Knock out the proper hole pattern in the back plate to mount to a standard junction box. Place a support on either side of the knock outs to be removed and then knock out with screw driver</li> <li>2. Route AC supply wires through the center hole of the back plate</li> </ol>	 <p>4</p> <ol style="list-style-type: none"> <li>1. Make electrical connections</li> <li>2. Connect battery only after AC power has been provided to the unit.</li> <li>3. Align snaps and push housing directly onto back plate.</li> </ol>	 <p>5</p>